

BUILDERS PACK

Add: 79 Emjay Blvd. Brentwood New York USA 11717
 Tel: 516-218-5599 / E-mail: Service@builderspack.com
 Web: www.builderspack.com

SIMPLY RELIABLE

Built in Sensor



SKU:78-20177-A

1. DC input
2. Compact sized suitable for ceiling light, troffer , triproof light, LED tube and etc.
3. Remote control.
4. 5 year warranty.



On/off control



Detection area



Hold time



Stand-by period



Stand-by dimming level



Remote control setting



Detection Coverage (Unit: m)

This figure indicates the maximum distance at the highest mounting height with 100% sensitivity.

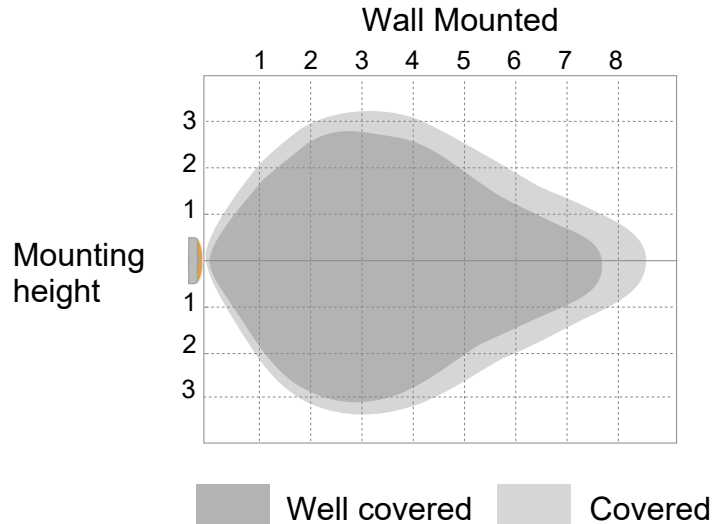
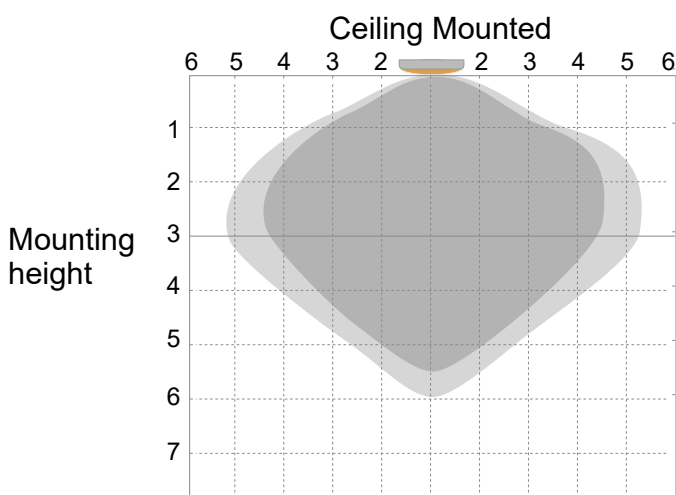

BUILDERS PACK

Add: 79 Emjay Blvd. Brentwood New York USA 11717
Tel: 516-218-5599 / E-mail: Service@builderspack.com
Web: www.builderspack.com

SIMPLY RELIABLE

Technical Data

Operating voltage	10.5-15V DC (supply current>50mA)
Operating current	<30mA
Output	DIM/1-10V
Stand-by power	<0.5W
Control line	Cable length 300mm, Black 12V, Purple DIM+, Yellow DIM-
Detection area	100%/75%/50%/25%
Hold-time	5s/30s/1min/3 min/5min/10min/20min/30min
Daylight threshold	2lux/10lux/30lux/50lux/80lux/120lux/Disable
Stand-by period	0s/10s/30s/min/5min/10min/30min/+∞
Stand-by dimming level	10%/20%/30%/50%
Microwave frequency	5.8GHz±75MHz
Microwave power	<0.3mW
Mounting height	Max. 5m (ceiling mounted)
Detection range	DxH. (Radius)1.5-4mx5m (ceiling mounted)
Detection angle	360°(ceiling mounted); <150° (Wall Mounted)
Operating temperature	-40°C~+80°C
Size	2.60"*0.81"*0.48"
Warranty	5 years

Note: Different applications and places will make different detection distance, our result is just for your information.

Motion sensor setting and dimming setting please refer to remote control.

BUILDERS PACK

Add: 79 Emjay Blvd. Brentwood New York USA 11717
Tel: 516-218-5599 / E-mail: Service@builderspack.com
Web: www.builderspack.com

SIMPLY RELIABLE

Mechanical Structure

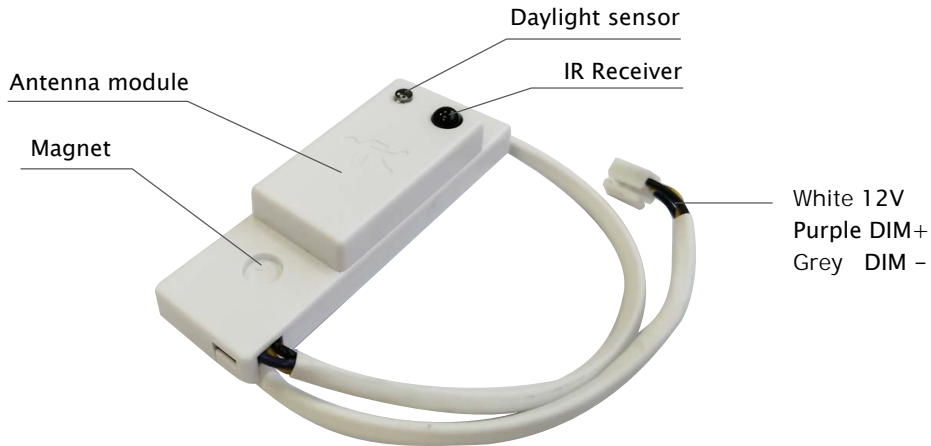

Wiring Diagram

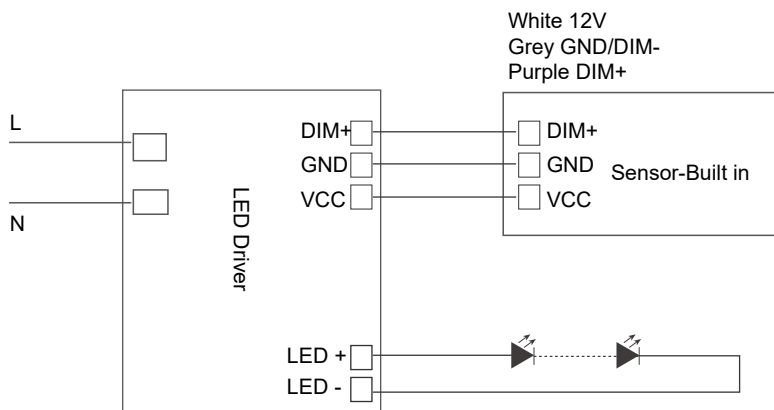

Installation Method

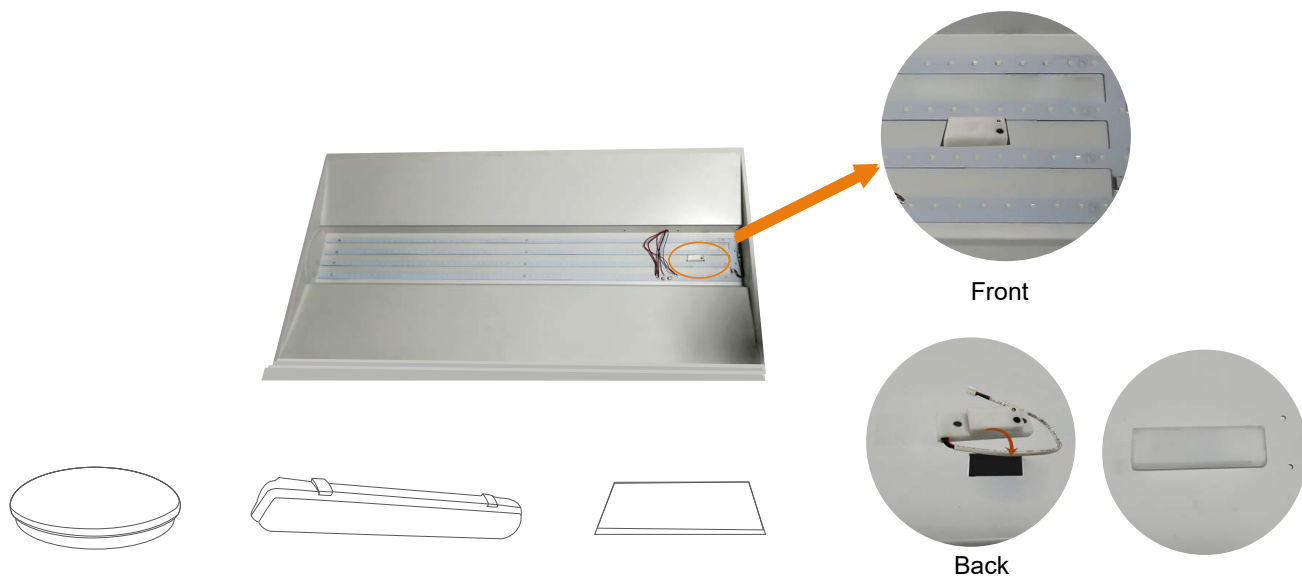

Suitable fixtures:
ceiling light, troffer, triproof light, batten light, linear light, LED tube and etc.

BUILDERS PACK

Add: 79 Emjay Blvd. Brentwood New York USA 11717
Tel: 516-218-5599 / E-mail: Service@builderspack.com
Web: www.builderspack.com

SIMPLY RELIABLE

Application

1. Automatically ON/OFF function

The Stand-by period is set to "0s".

Light on when detect movement and off after people leave at night.

Applications: Corridor, Staircase.

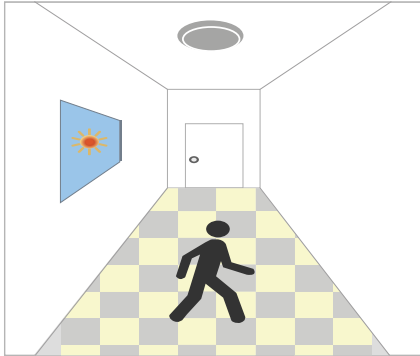

With sufficient daylight, even when motion detected, light remains OFF.

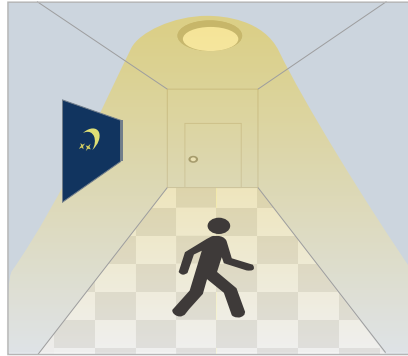

With insufficient daylight, when motion detected, light ON.

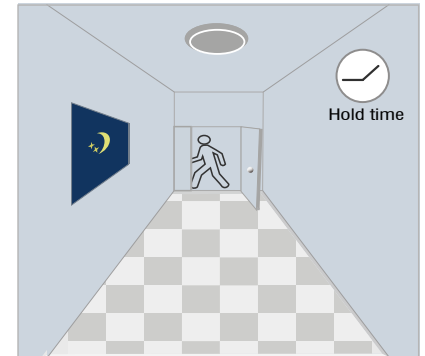

After the last detection and the present hold time elapsed, light OFF.

2. No daylight function

The daylight threshold is set to "Disable".

Light on when detect movement, After people leave, Light off after stand-by period.

Applications: Dim places such as Basement Parking, Underpass.



When motion is detected, the sensor will switch on the light to 100% brightness.

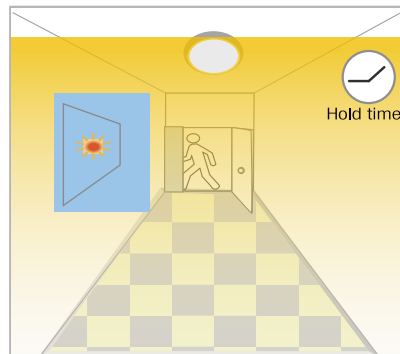

After people leave the detection area, light remains 100% brightness within hold time.

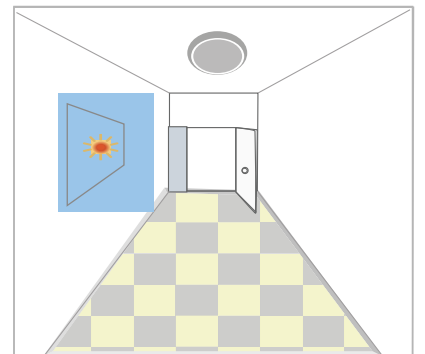

After the last detection and the present hold time elapsed, light OFF

BUILDERS PACK

Add: 79 Emjay Blvd. Brentwood New York USA 11717
Tel: 516-218-5599 / E-mail: Service@builderspack.com
Web: www.builderspack.com

SIMPLY RELIABLE

3. Function Demo - Dimmable control/Corridor function

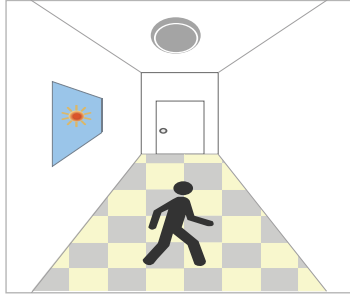

With sufficient daylight, even when motion detected, light remains OFF.



With insufficient daylight, when motion detected, light ON.

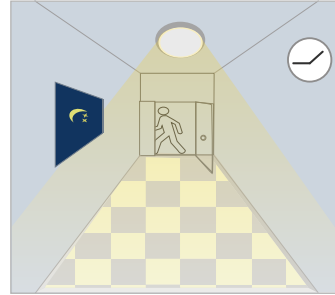

After last detection, the light will be dimmed down to the stand-by dimming level (10%, 20%, 30%, 50%) after holdtime.

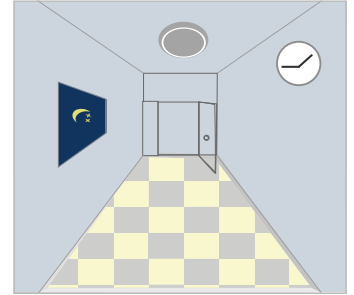

After the stand-by period, light OFF.

Attention



1. Please read the instructions carefully before using this product and keep it well for all users to read at any time.
2. The sensor should be installed by qualified electrician and ensure power is off before the installation.
3. We reserve the right to modify any incorrect text, image and necessary technical parameters.
4. Any unauthorized modification is forbidden, otherwise all guarantees will be immediately invalid.

Installation Precautions

1. Microwave sensor can be installed in any lamp except the one with full metal shell.
2. The detected surface cannot be shielded by metal objects.
3. Make sure the microwave module is completely exposed outside.
4. The detection surface of the sensor module shall be installed facing the detection area.
5. Should be kept away from the driver to avoid interference generation and lamp flashing.
6. Wiring must be strictly in accordance with the wiring diagram to avoid short circuit.

BUILDERS **PACK**

Add: 79 Emjay Blvd. Brentwood New York USA 11717
Tel: 516-218-5599 / E-mail: Service@builderspack.com
Web: www.builderspack.com

SIMPLY RELIABLE

Application Environment

1. Suitable for indoor installation to avoid false triggering due to external factors such as rain, wind or tree swing.
2. Shall not be installed in the place with all four metal shelters and small space (such as galvanized-iron roof).
3. Shall note be mounted installation, so as to avoid false trigger caused by the lamp itself shaking.
4. Shall not be installed next to large operating machines such as ventilator/ceiling fan to avoid false triggering caused by machine vibration.